

1.1 Reflected light – bright field lighting

Influence of the lighting angle

Bright field lighting is a type of reflected-light lighting. Imagine the object plane as a perfectly flat reflector. If the lighting is arranged so that light is reflected directly back into the camera, this is referred to as a bright field arrangement.



Partial bright field

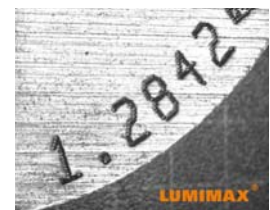

Bright field arrangement

This type of lighting is therefore especially suited to:

- Surface finish inspection
- Imaging of embossed, dot-peened und laser-cut characters and codes

Wavelengths

Bright field
Coaxial reflected lighting

View video:

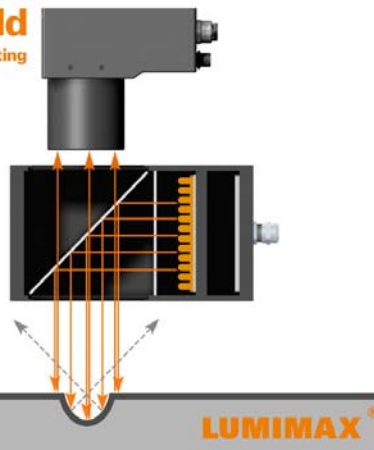

One way to achieve a bright field setup is to use coaxial reflected lighting, for example. For this type of lighting, a diffuse, homogeneous light source is mounted over a semi-transparent reflector directly in the beam path of the lens. This provides very homogeneous, shadow-free lighting for the object. The light beam hits flat surfaces vertically and is reflected directly back into the camera. Surface irregularities deflect the light, however, and therefore appear dark. The type of lighting is recommended for illuminating strongly reflective and mirror-like surfaces.

Optical filters

Flash vs. continuous

Video can be viewed at <http://www.iimag.de/lumimax/wissenswertes/video-hellfeld-koaxial.html>

On each pass through the reflector, however, 50% of the light output is lost. Accordingly, only 25% of the light transmitted reaches the camera. To achieve a well-lit, high-contrast image nonetheless, the coaxial reflected lighting is used at a short distance from the test object.

Fluorescence applications

An alternative bright field arrangement, also suitable for larger working distances as well as matt and rough surfaces, is based on the Law of Reflection as explained in “Chapter 1 – Influence of the lighting angle”:

angle of light incidence α = angle of light reflection β

If the lighting is positioned at a certain angle to the object plane, the camera must be tilted to the same angle – but in the opposite direction to the perpendicular. In this way, the light beam hits flat surfaces vertically and is reflected directly back into the camera.

As with coaxial reflected lighting, the light beam is deflected by irregularities, which means that these will be shown as dark areas on an otherwise bright background.



Video can be viewed at <http://www.iimag.de/lumimax/wissenswertes/video-hellfeld-spot.html>

Lighting systems for the reading and verification of codes